

Z E N O N®
GRP DAYLIGHT SOLUTIONS

ZENON ARC - BARREL VAULT ROOFLIGHT SYSTEM

INSTALLATION RECOMMENDATIONS

ZENON ARC DIMENSIONS AND FIXING LOCATIONS

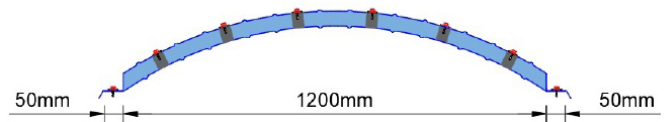
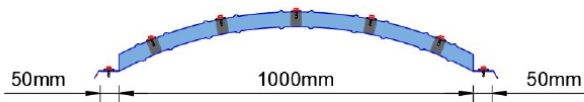

ZENON ARC FIXING DETAILS

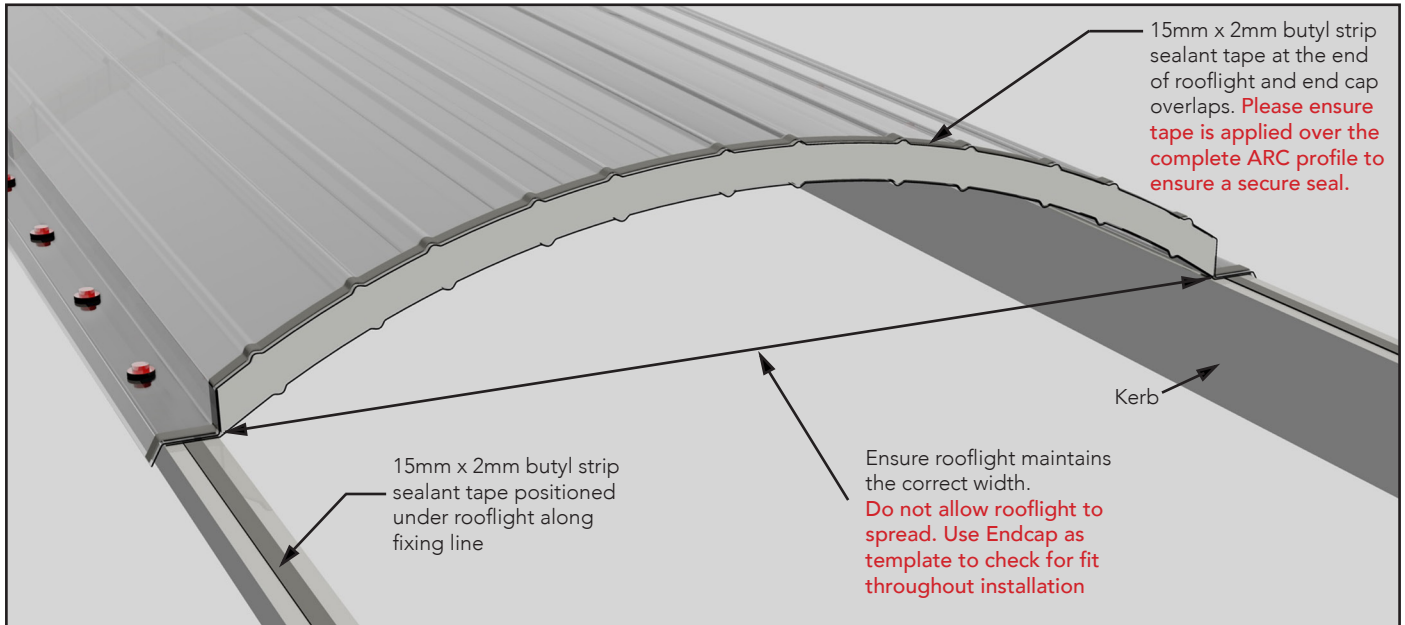

TYPICAL KERB MOUNTING DETAIL

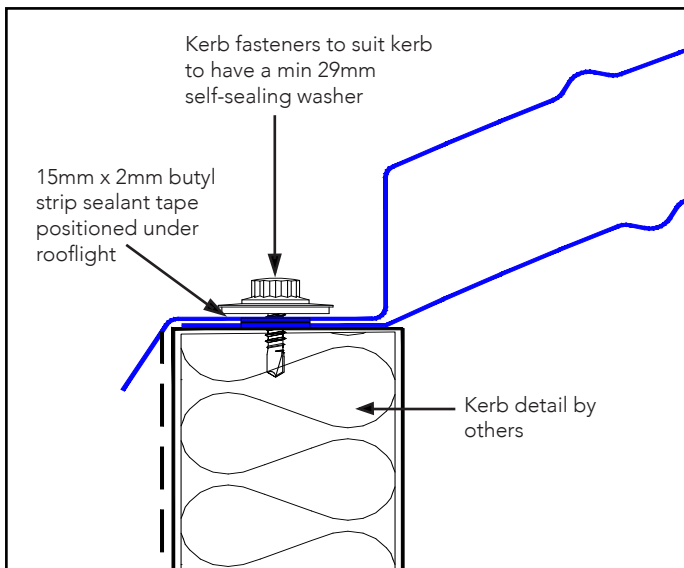

TYPICAL STANDING SEAM KERB DETAIL

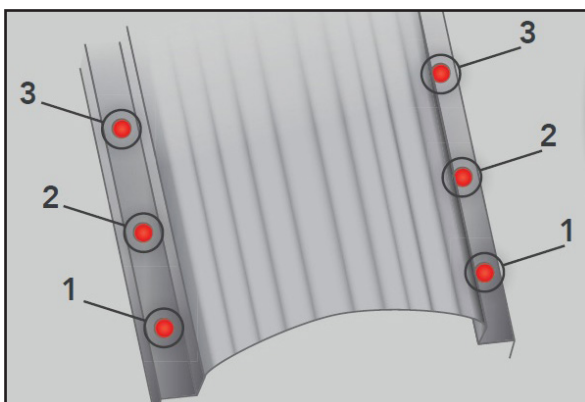
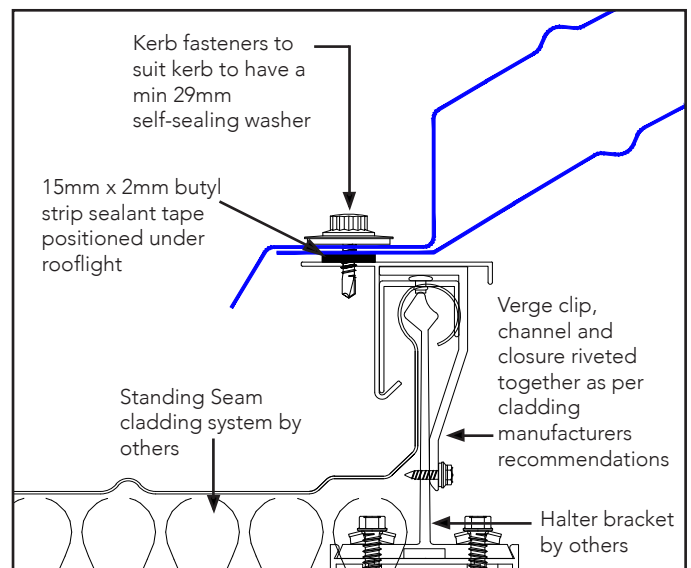

IMPORTANT INFORMATION:

When installing ZENON ARC to curved roofs, the panels should be fixed progressively along the kerb to avoid any flattening on the panel.

END CAP ASSEMBLY - OVERLAP ONTO ROOFLIGHT

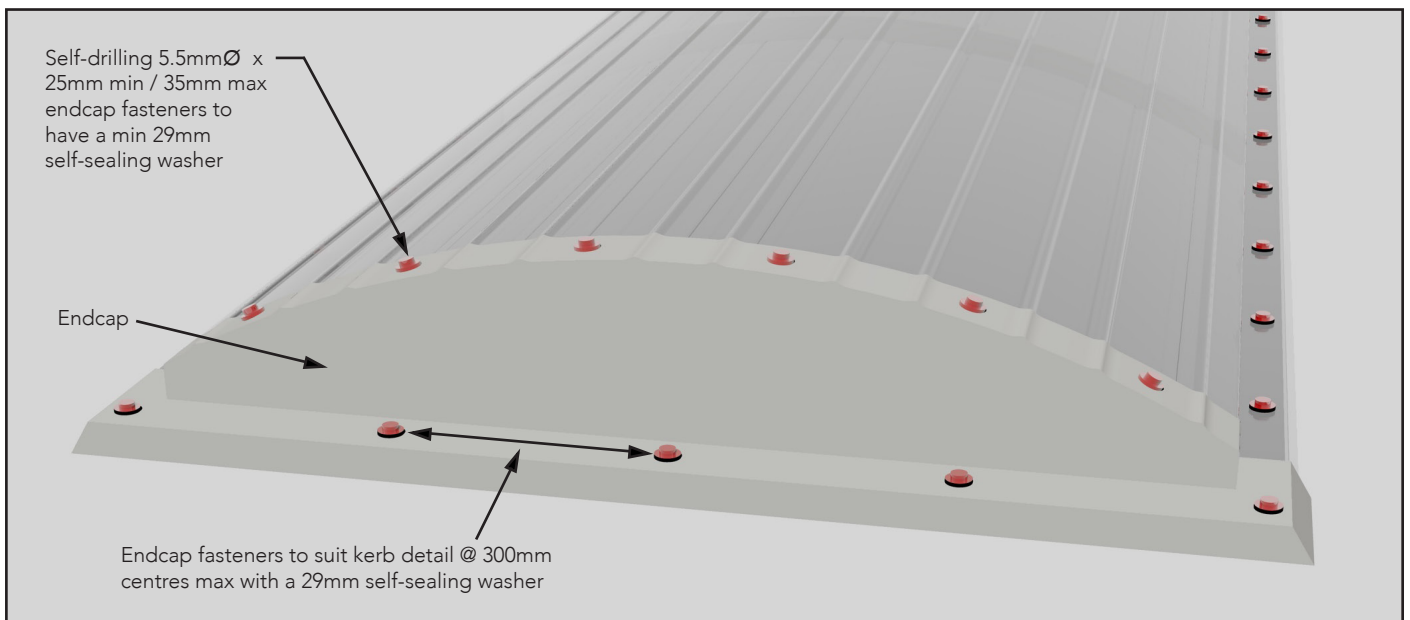
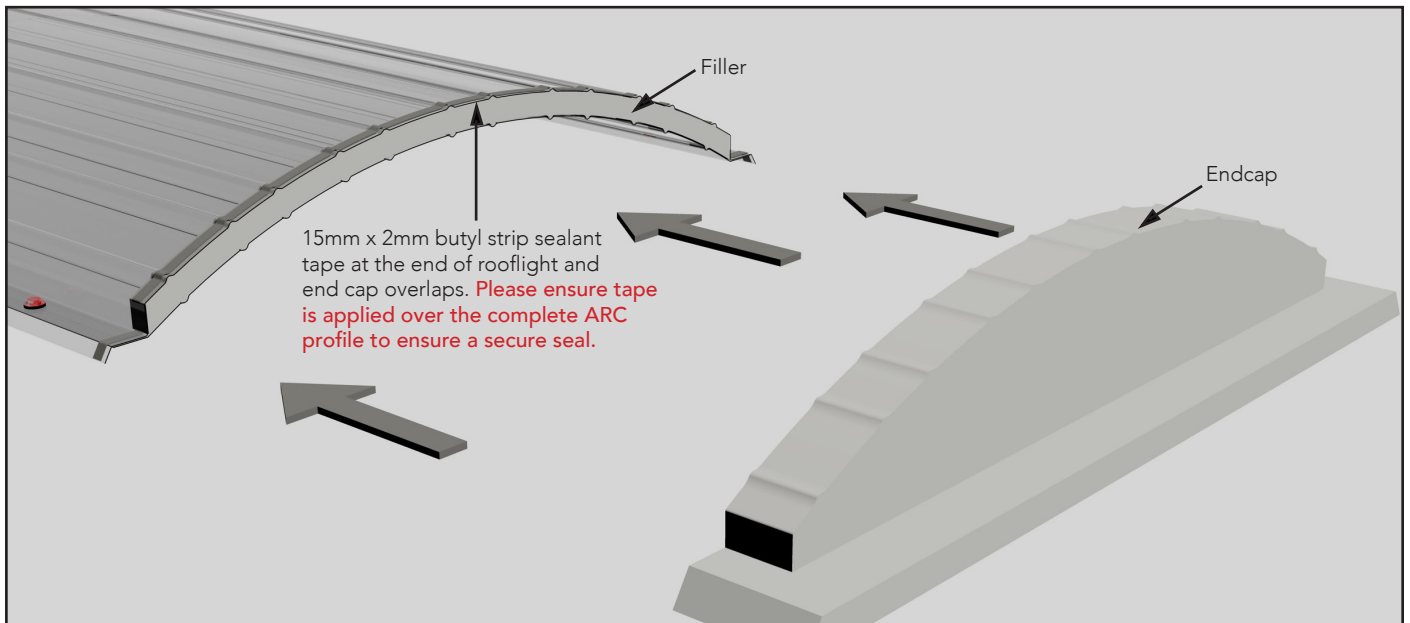

ROOFLIGHT END CAP OVERLAP

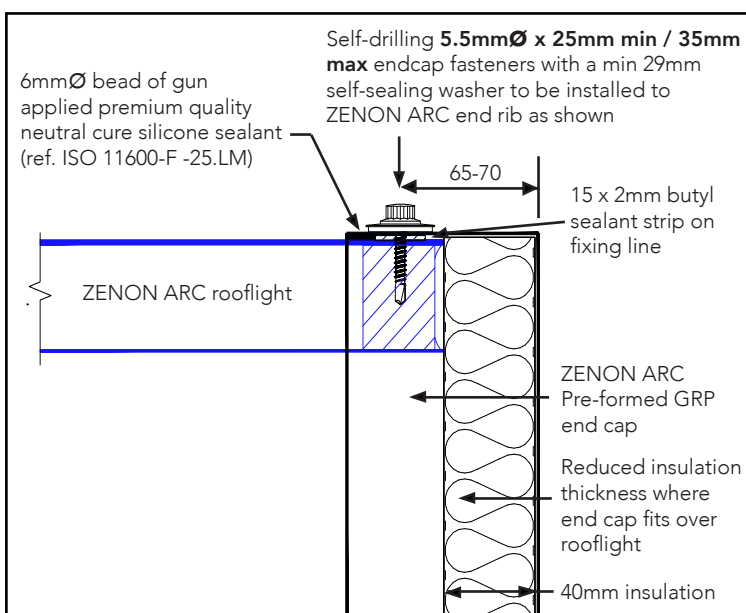

For horizontal kerb applications, it is recommended that the rooflight end caps be fitted over the top of the rooflight panel. Where the rooflight run follows the slope of the roof, the end cap at the lower end should be fitted below the rooflight end lap.

END CAP ASSEMBLY - OVERLAP ONTO END CAP

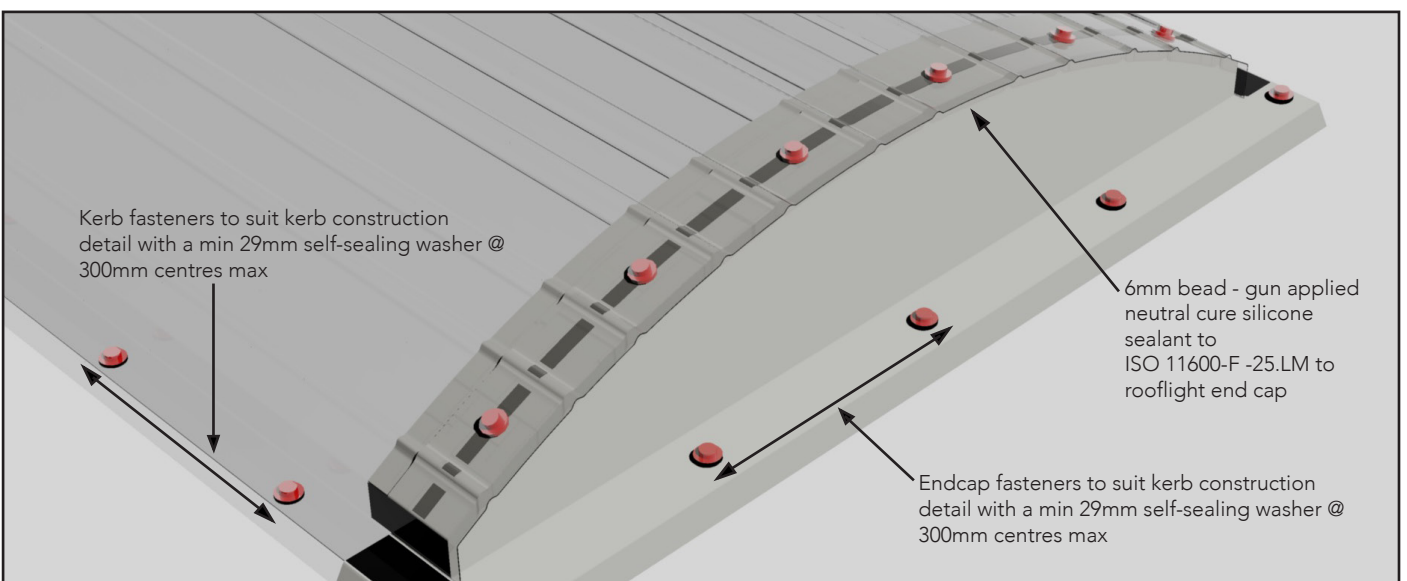
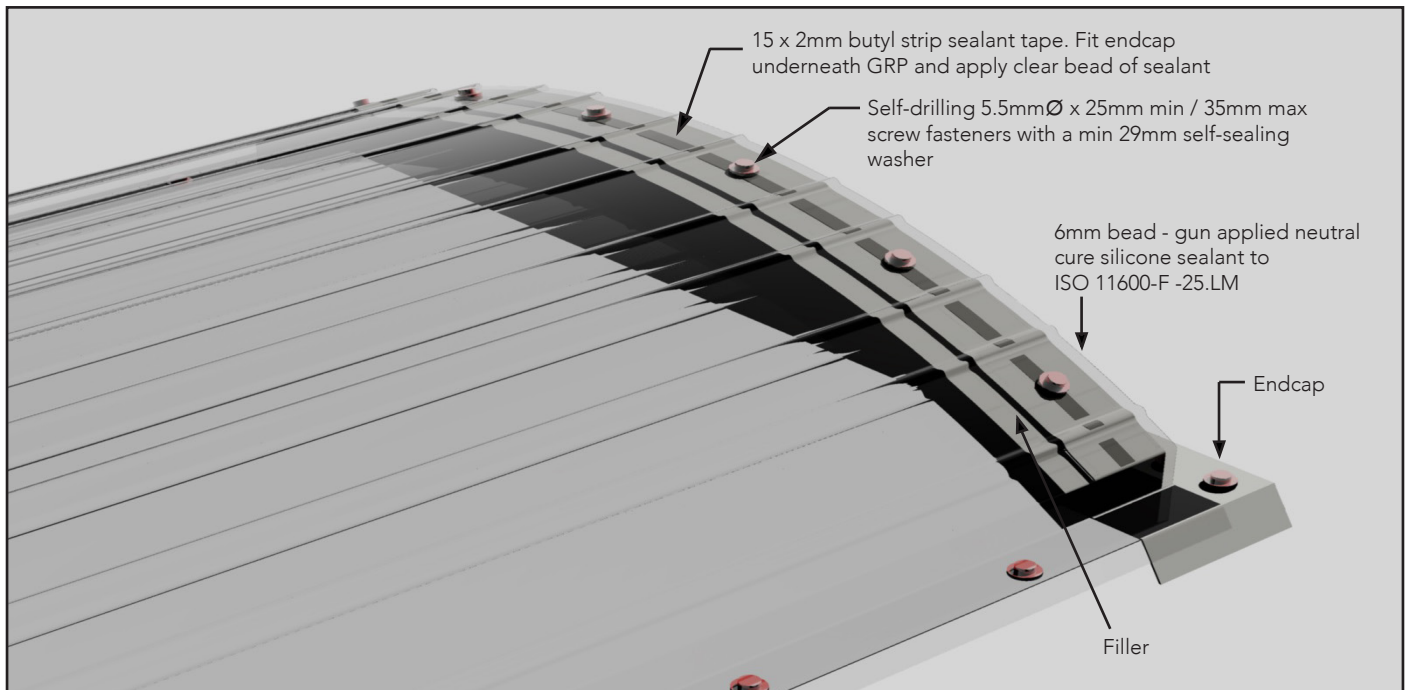
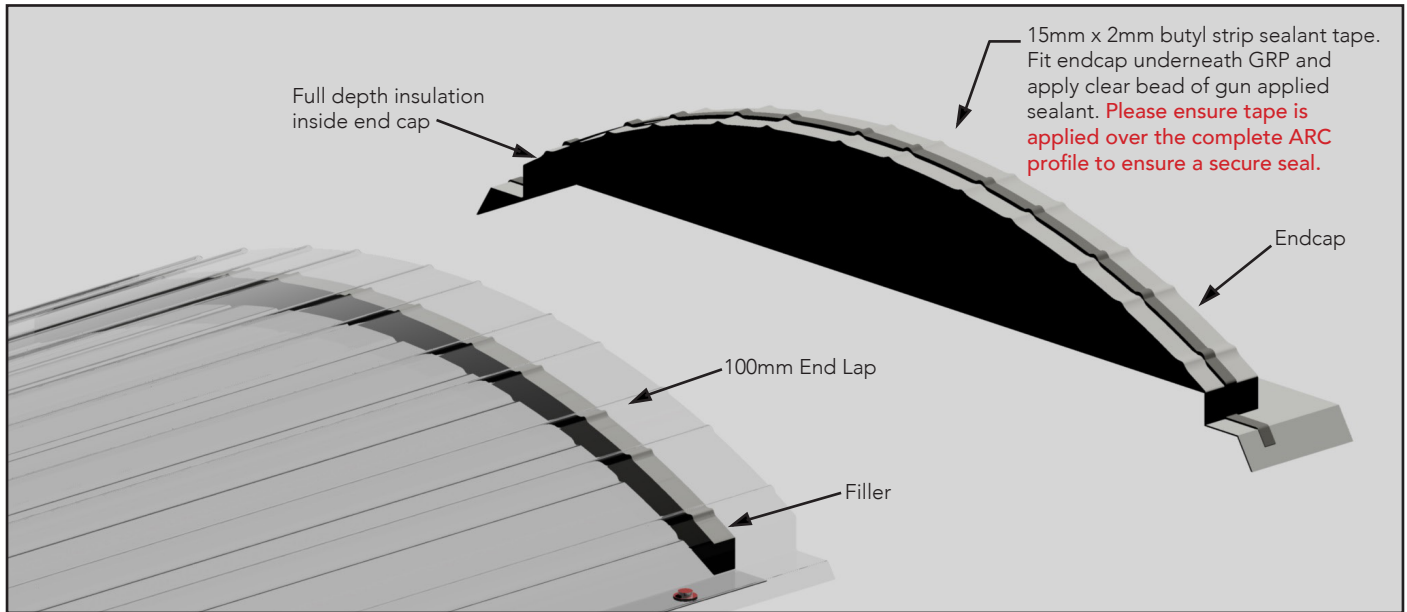

ROOFLIGHT OVERLAP ONTO END CAP

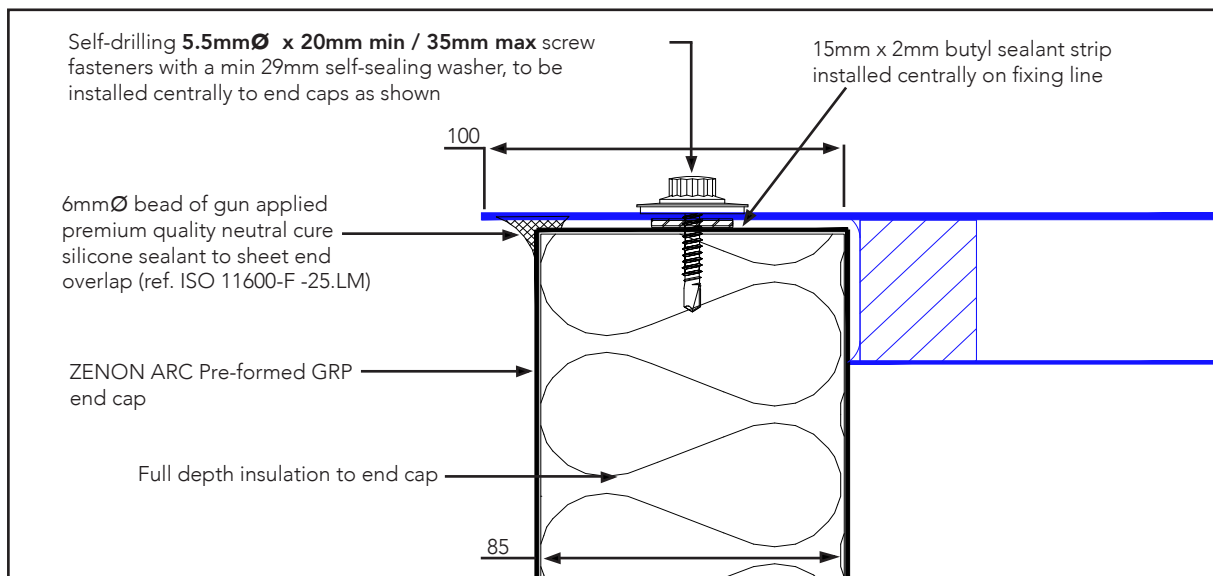

ROOFLIGHT TO ROOFLIGHT JOINT

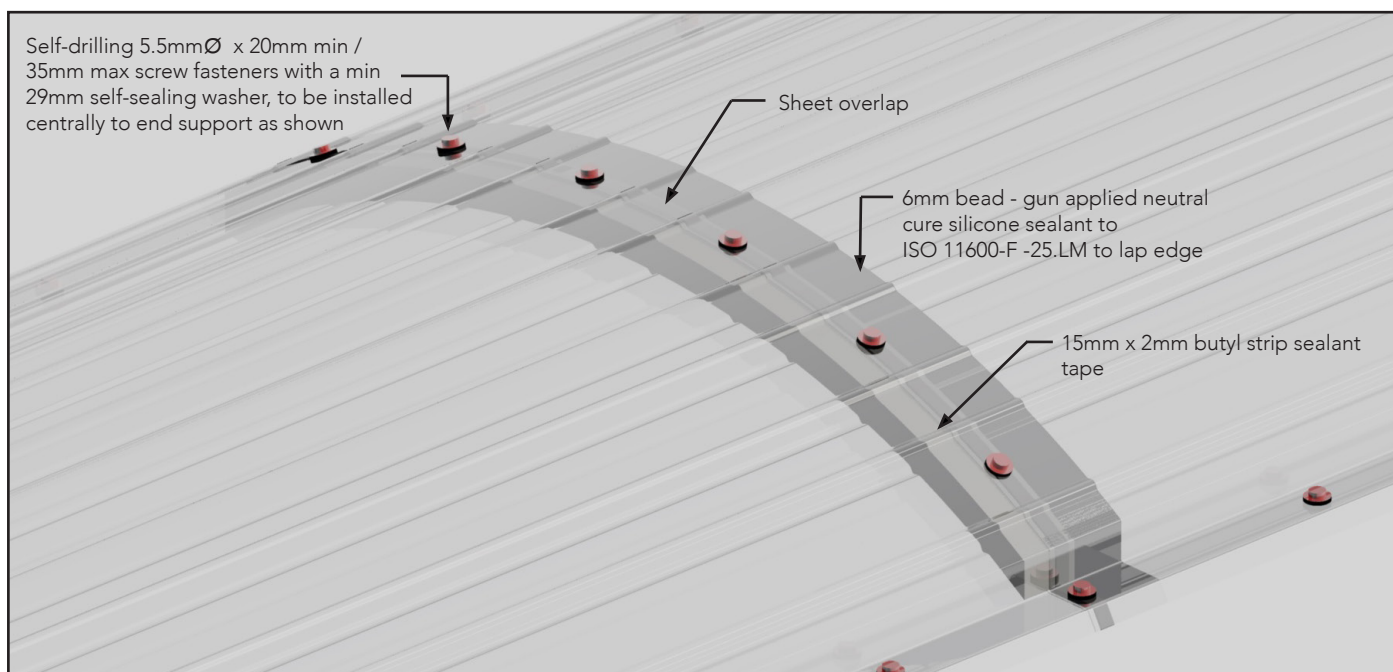

ROOFLIGHT TO ROOFLIGHT JOINT DETAIL

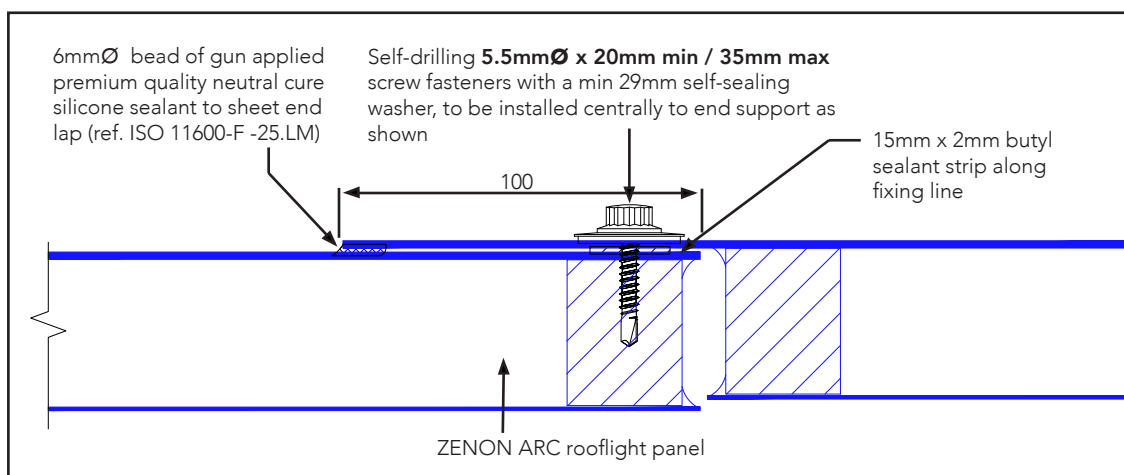

Zenon Pro

The Zenon Pro rooflight range for in-plane installation in profiled metal cladding systems is manufactured from polyester resins with traditional glass fibre reinforcement. These products are available in a range of nominal weights from 1.8kg/m² to 5.4kg/m² manufactured and CE marked in accordance with BS EN 1013:2012 + A1:2014.

Zenon Evolution

The Zenon Evolution range of low carbon rooflights, also manufactured and CE marked to BS EN 1013:2012 + A1:2014, uses state of the art reinforcement technology to deliver a truly innovative rooflight solution with excellent impact resistance and an improved service life.

The strength of the reinforcement allows the product to be manufactured using significantly less

resin than would be the case with traditional reinforcement techniques, resulting in a significant reduction in the embodied carbon and better profile definition providing a far better profile match resulting in a better fit and more reliable seal with the adjacent metal sheets, aiding weather proofing and airtightness.

Barrel Vault Rooflights

Zenon Arc and Zenon Archlight are two cost effective and robust Glass Reinforced Polyester (GRP) barrel vault rooflight systems.

Both systems provide excellent light transmission with good levels of diffused light distribution to the internal areas of the building, and are designed for simple installation onto kerbs or upstands in flat plane or curved roof structures and can be installed for roof-lighting application along ridgelines.

Insulator

Hambleside Danelaw manufactures a full range of site and factory assembled insulated rooflights (FAIRS) to match most cladding systems incorporating conventional multi-layer polycarbonate insulation options or the unique Insulator core for improved light transmission and a range of U-values from 1.8W/m²K down to 0.8W/m²K.



ZENON

LOW CARBON GRP DAYLIGHT SOLUTIONS

Zenon ARC is a brand of Hambleside Danelaw Limited

For further support on the enclosed Installation Recommendations or to find out more about the product range, please contact us using any of the following methods:

T : +44 (0)1327 701 920

E: sales@hambleside-danelaw.co.uk

www.hambleside-danelaw.co.uk

